

IO

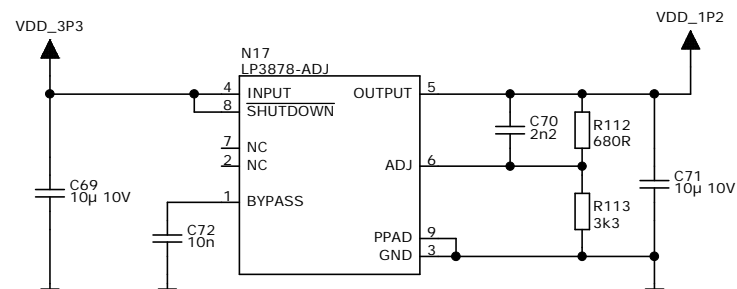

FPGA Core

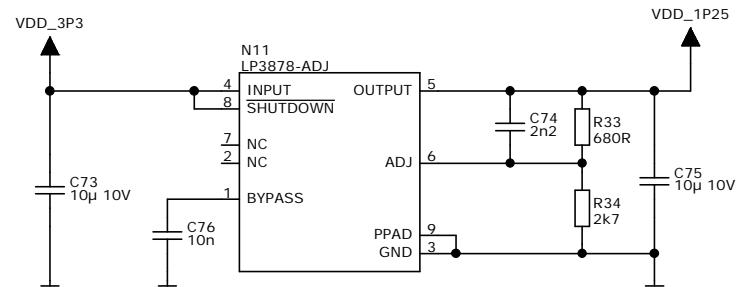

DSP Core

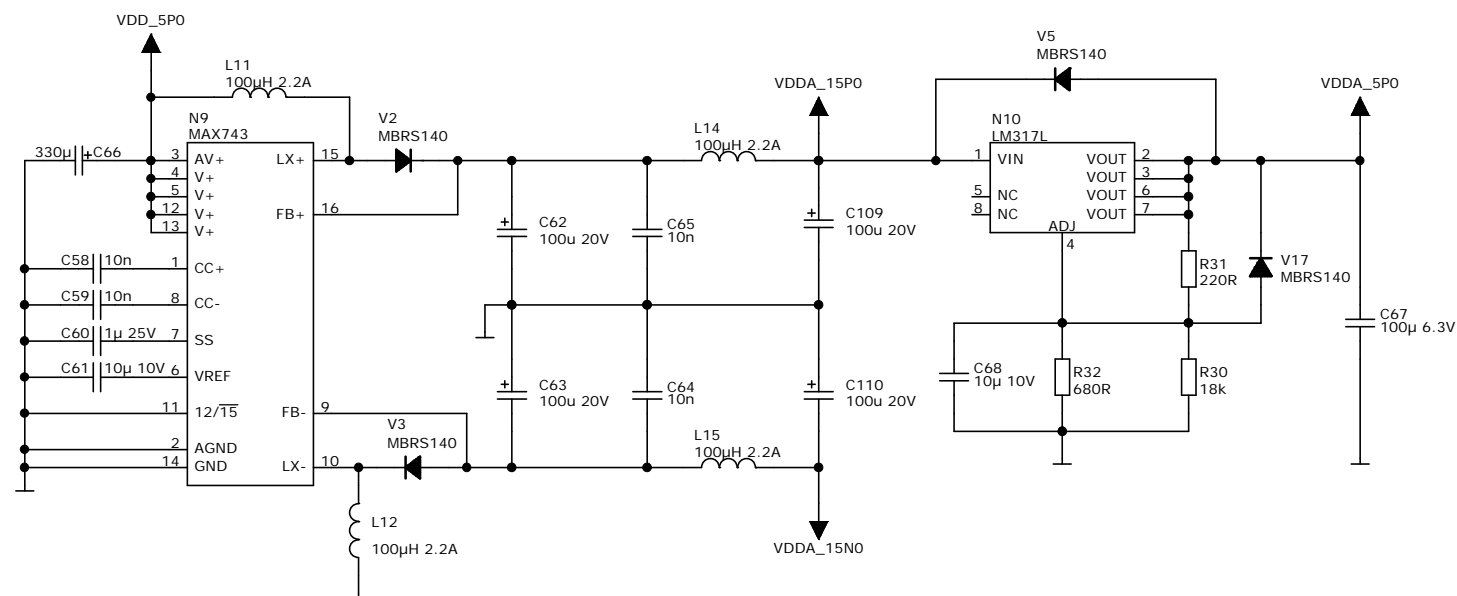
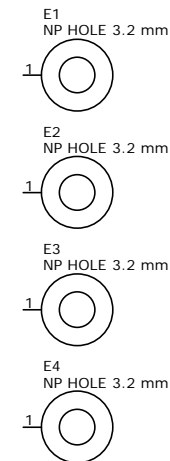

<p>JTA Design</p>	<p>DSP56371 Test Board</p>	
	<p>Power</p>	
<p>Design date 2008-04-16</p>	<p>File name DSP56371TestBoard.sch</p>	<p>Version 01 Sheet 1 OF 7</p>

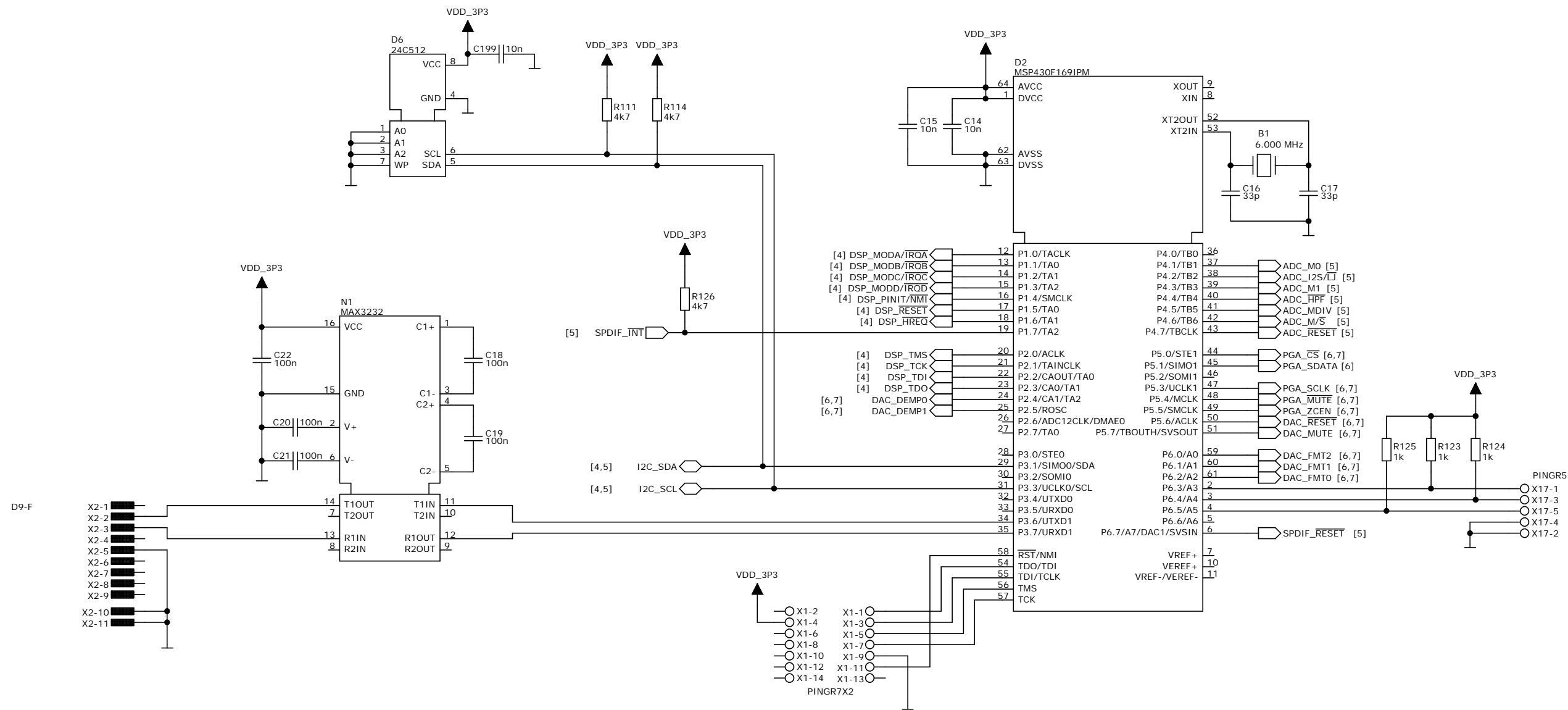

JTA Design	DSP56371 Test Board Debug interface	
	Design date 2008-04-16	File name DSP56371TestBoard.sch
		Version 01 Sheet 2 OF 7

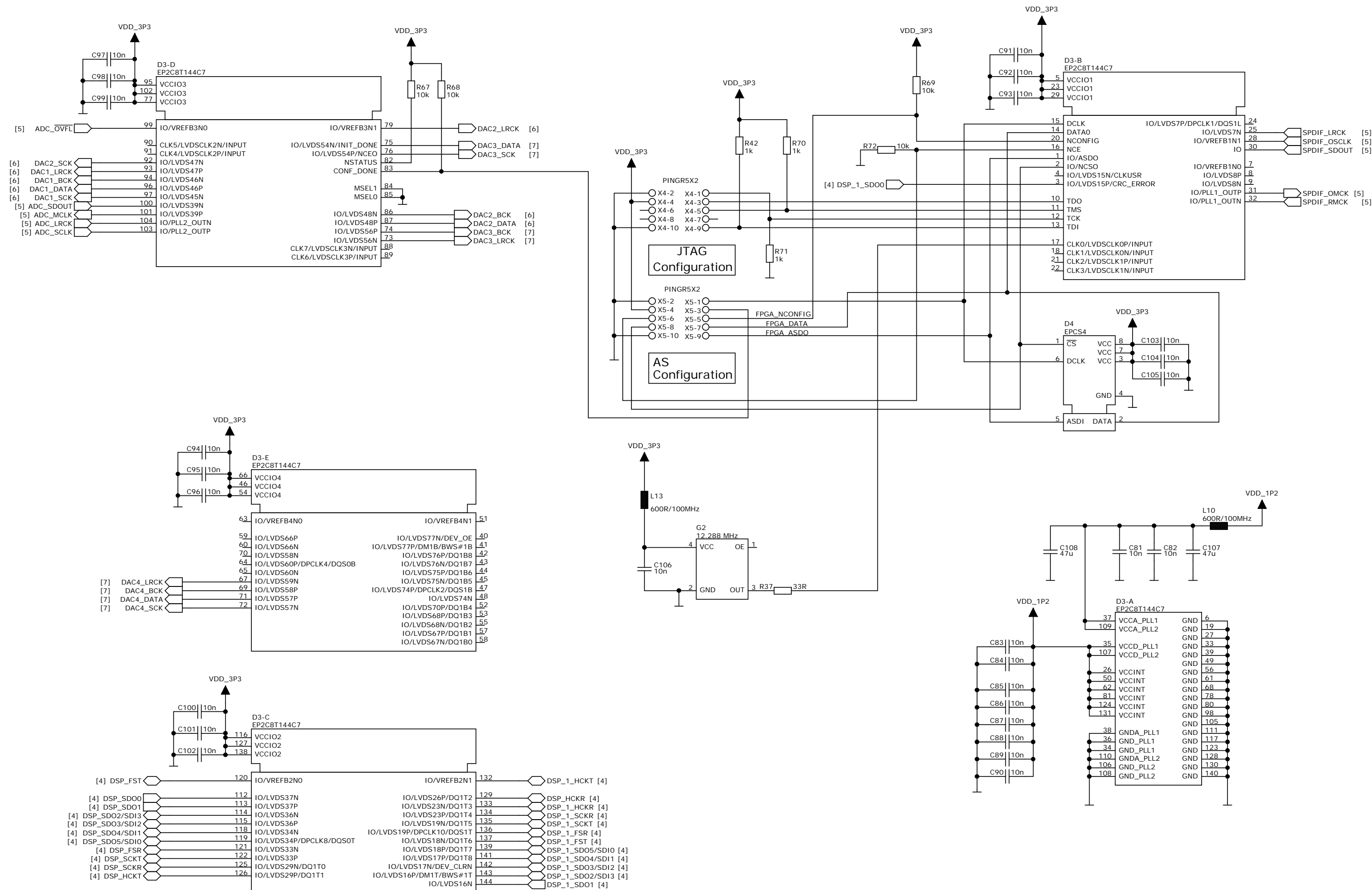

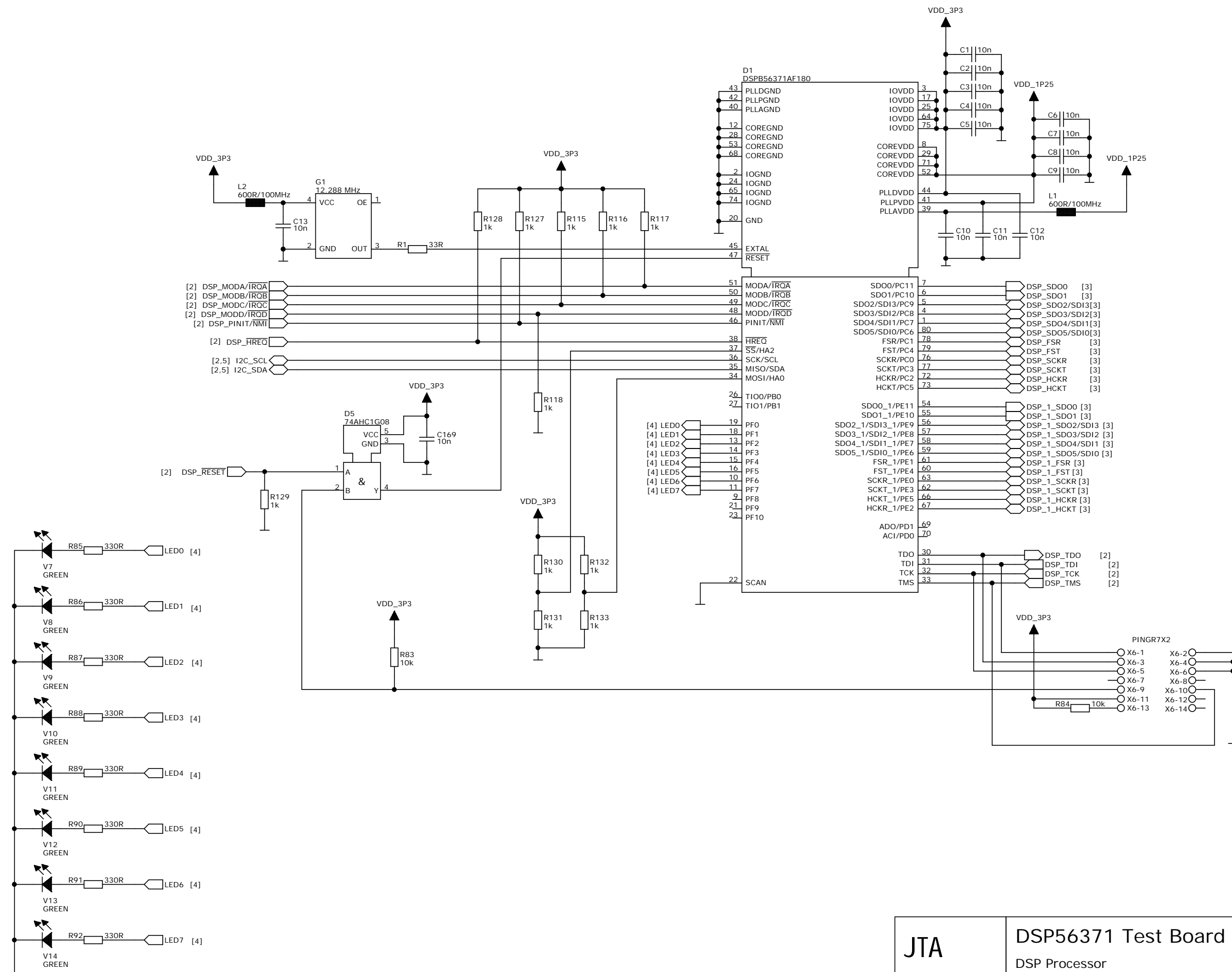

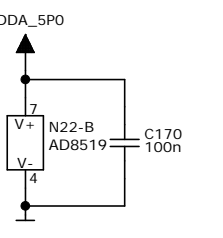
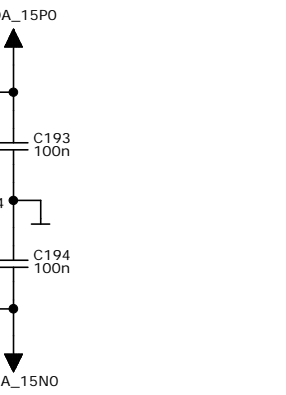
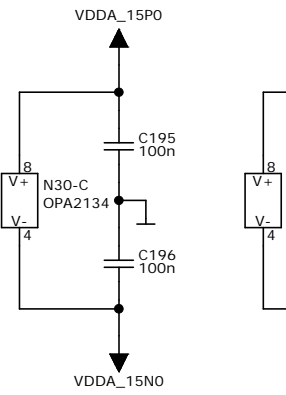
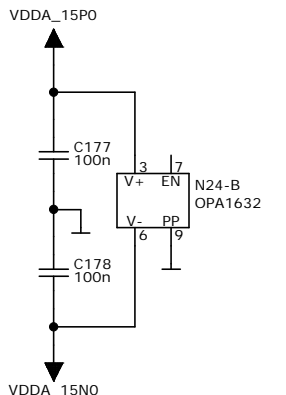
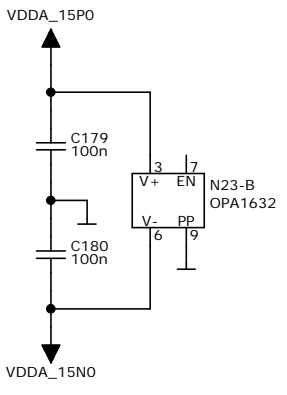
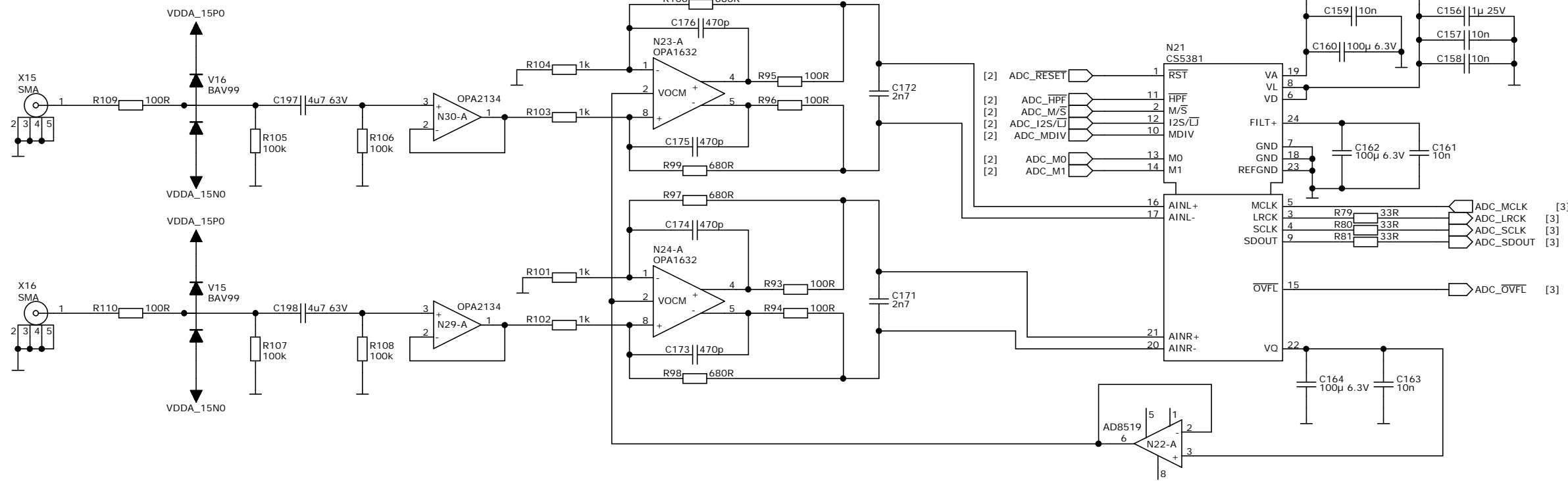
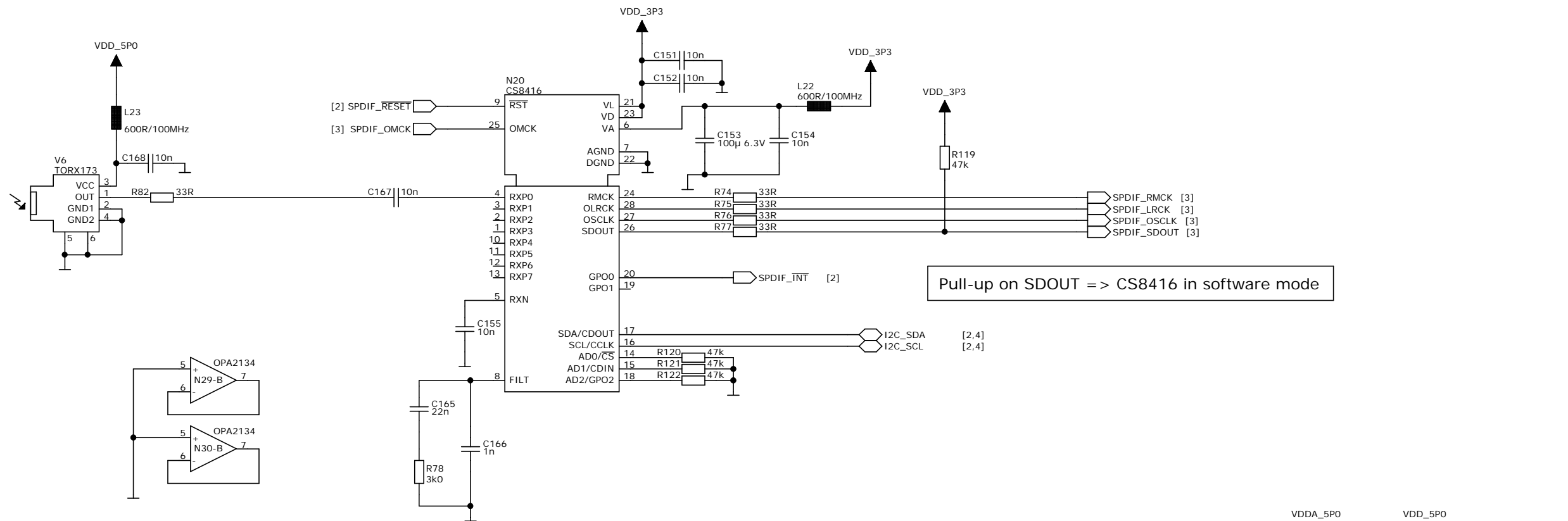

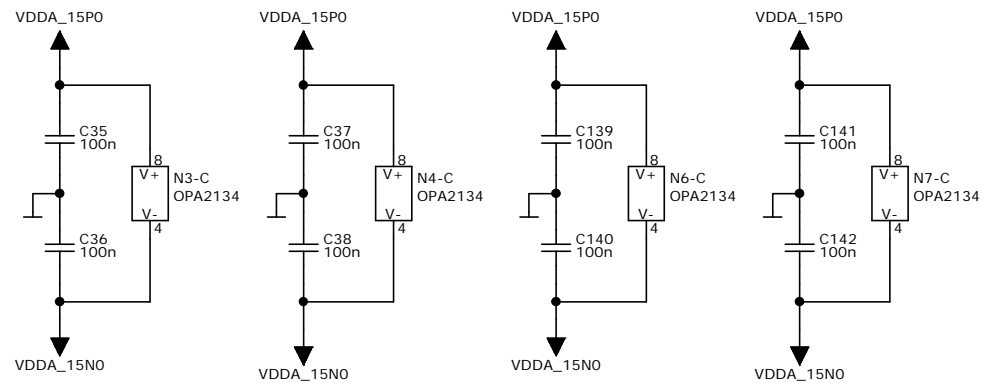
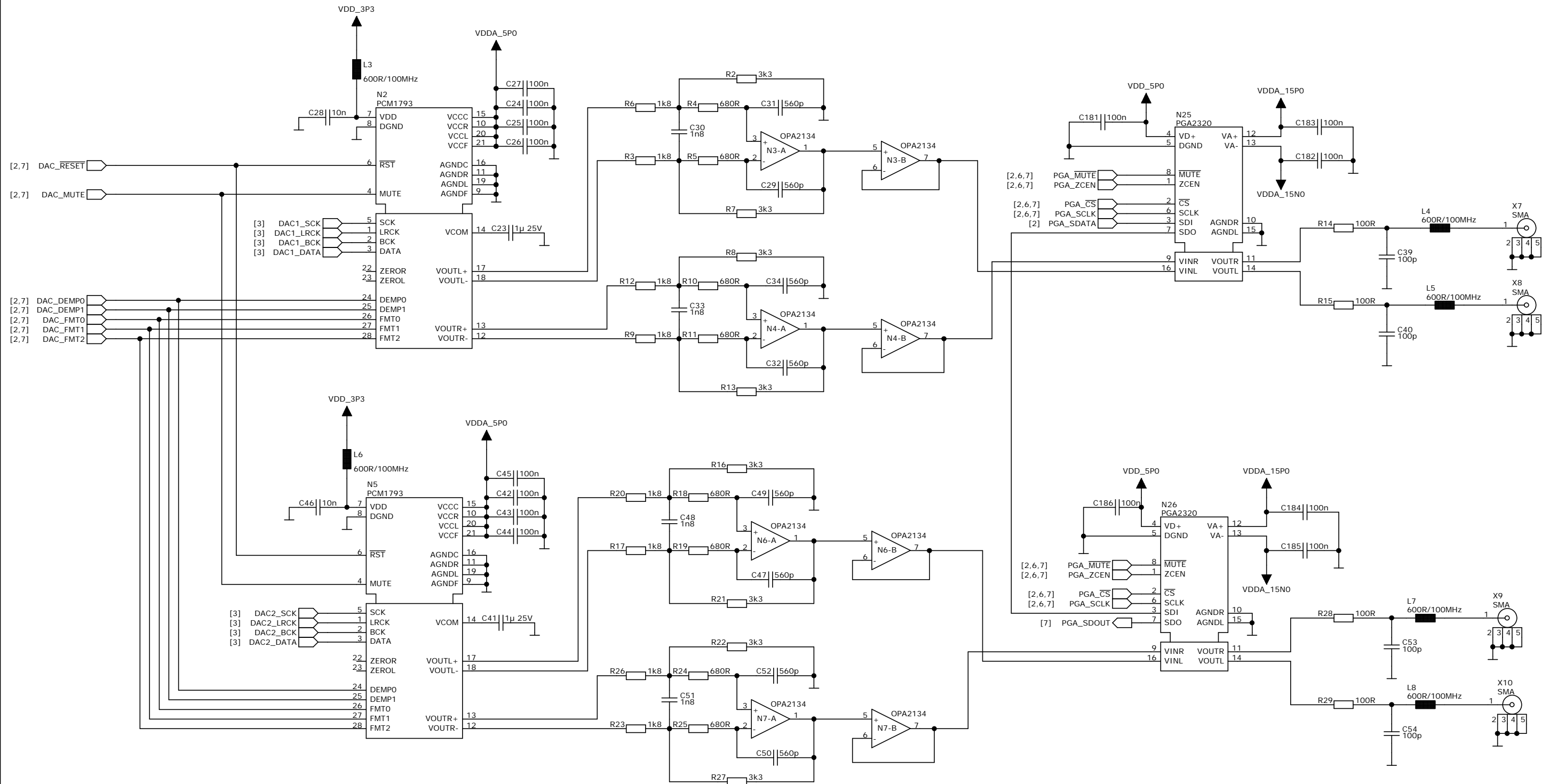

<p>JTA Design</p>	<p>DSP56371 Test Board DAC / analog out 1</p>	
	<p>Design date 2008-04-16</p>	<p>File name DSP56371TestBoard.sch</p>
		<p>Version 01 Sheet 6 OF 7</p>

