

JTA Design	Timing adapter MCU & Power	
	Design date	File name
	2009-09-20	TimingAdapter-01.sch
	Version 01	
	Sheet 1 OF 2	

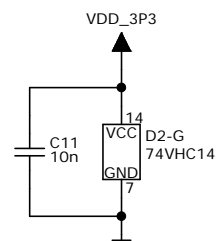
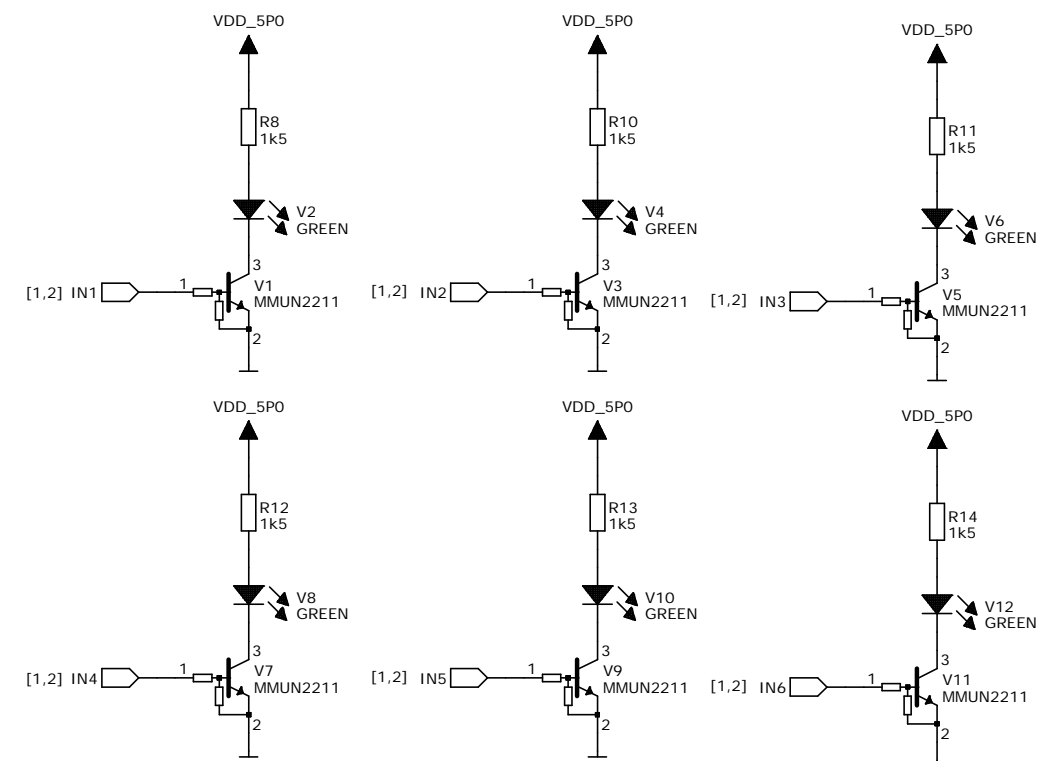
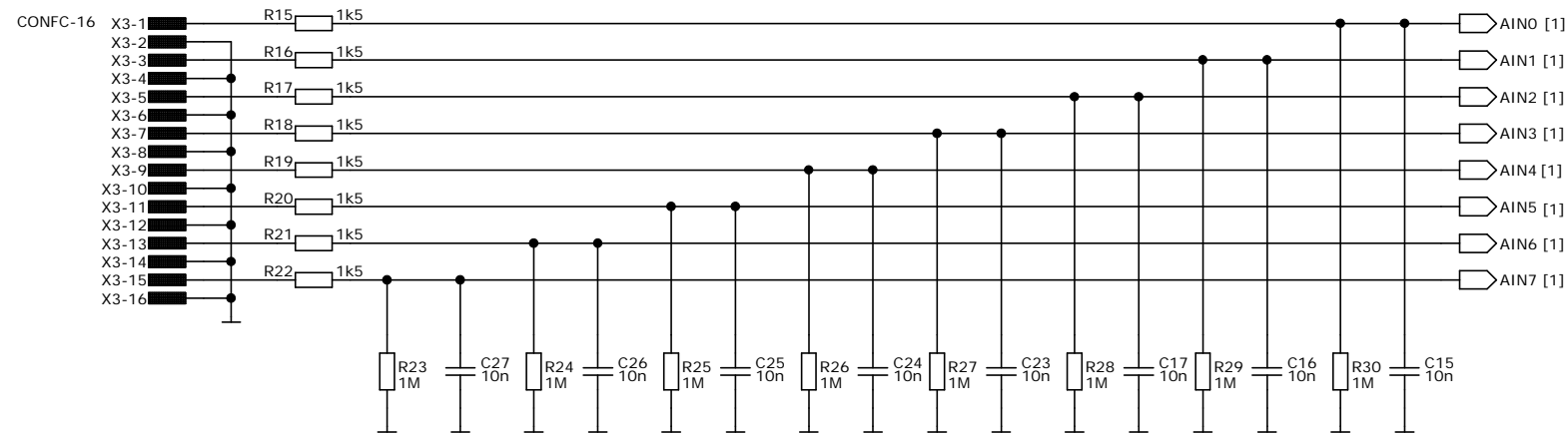
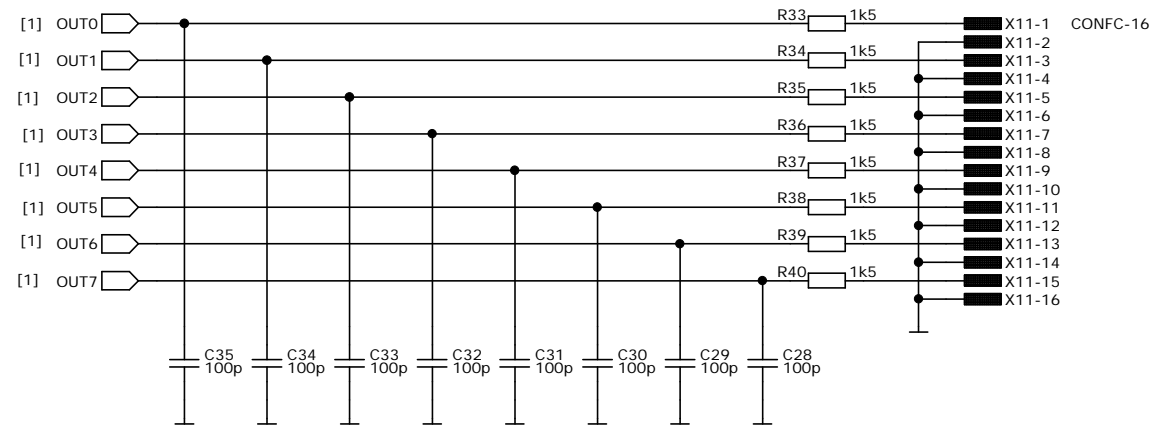
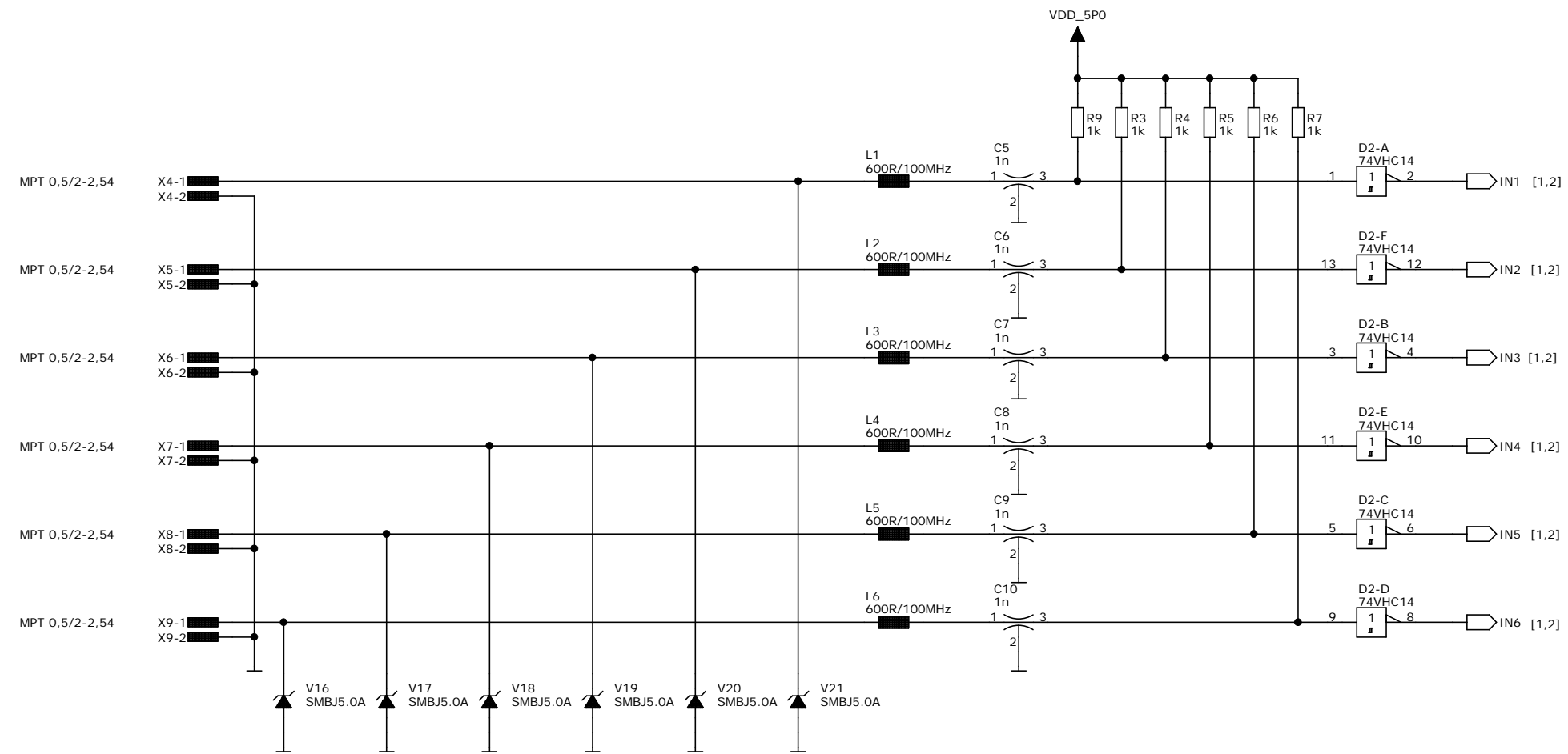

JTA Design	Timing adapter	
	Inputs	
	Design date 2009-09-20	File name TimingAdapter-01.sch
		Version 01 Sheet 2 OF 2