

JTA Design	Energy Logger	
	Ethernet	
Design date 2015-03-25	File name EnergyLogger-03.sch	Version 03 Sheet 2 OF 4

Photodetector interface

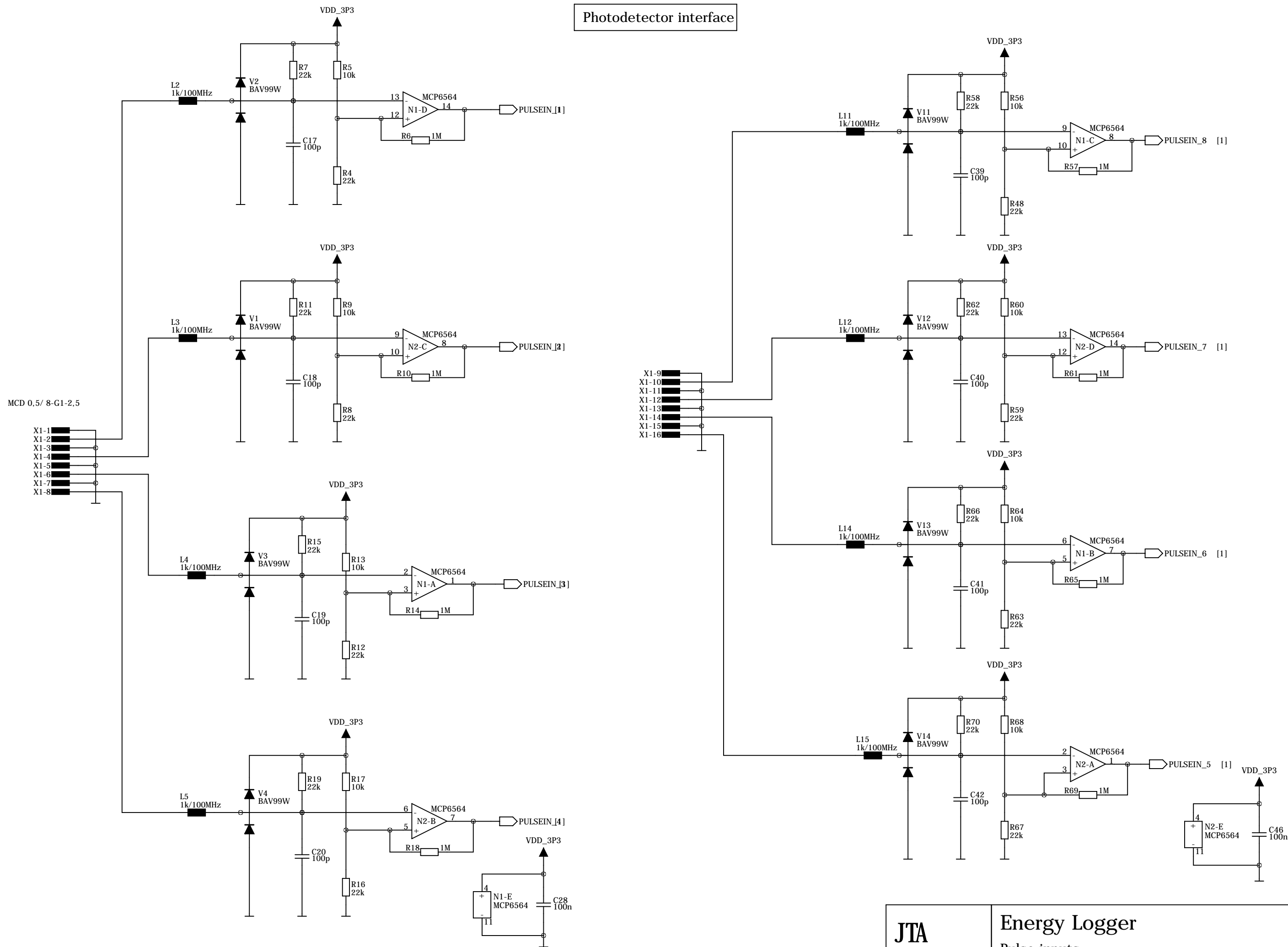

JTA
Design

Energy Logger
Pulse inputs

Design date	File name	Version
2015-03-25	EnergyLogger-03.sch	03
Sheet		3 OF 4

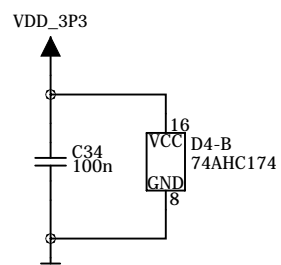
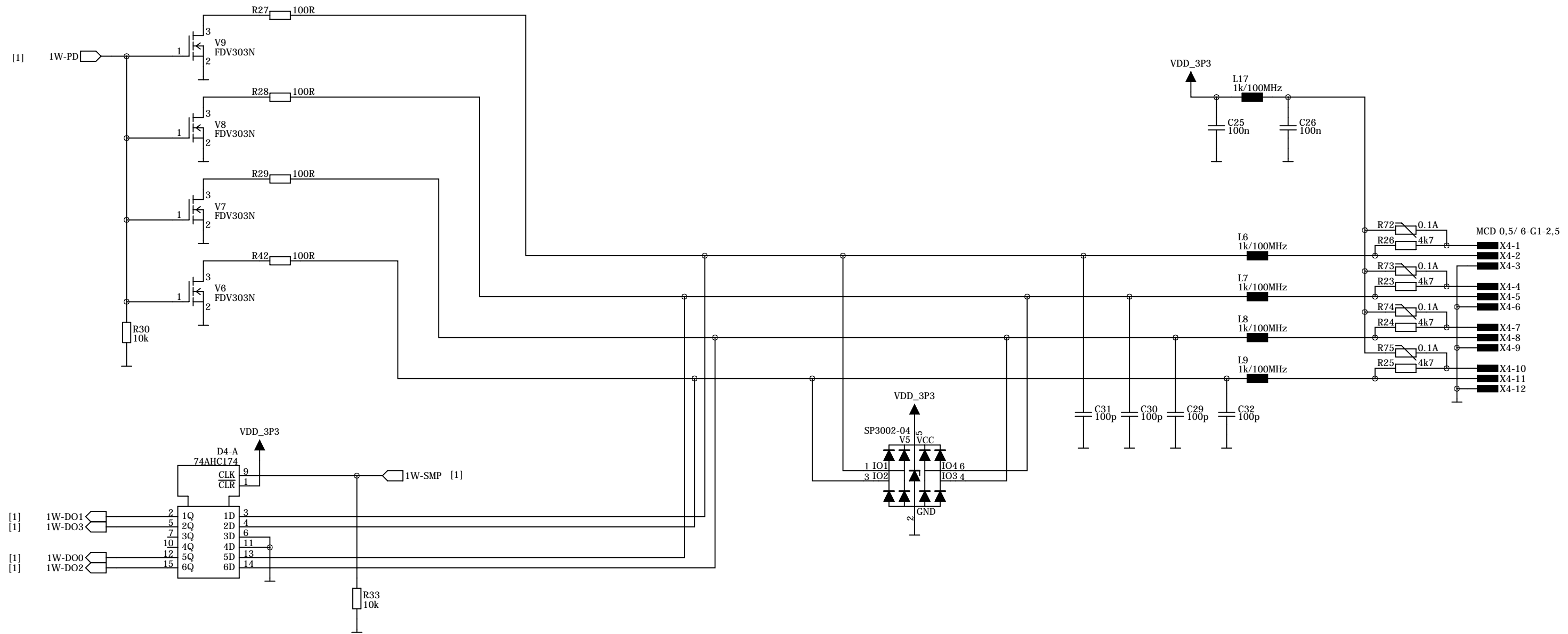

JTA Design	Energy Logger 1-wire interface	
	Design date 2015-03-25	File name EnergyLogger-03.sch
	Version 03 Sheet 4 OF 4	