

JTA Design	Crossover-amplifier-network		
	DAC		
Design date	File name	Version 01	
		Sheet 1 OF 4	

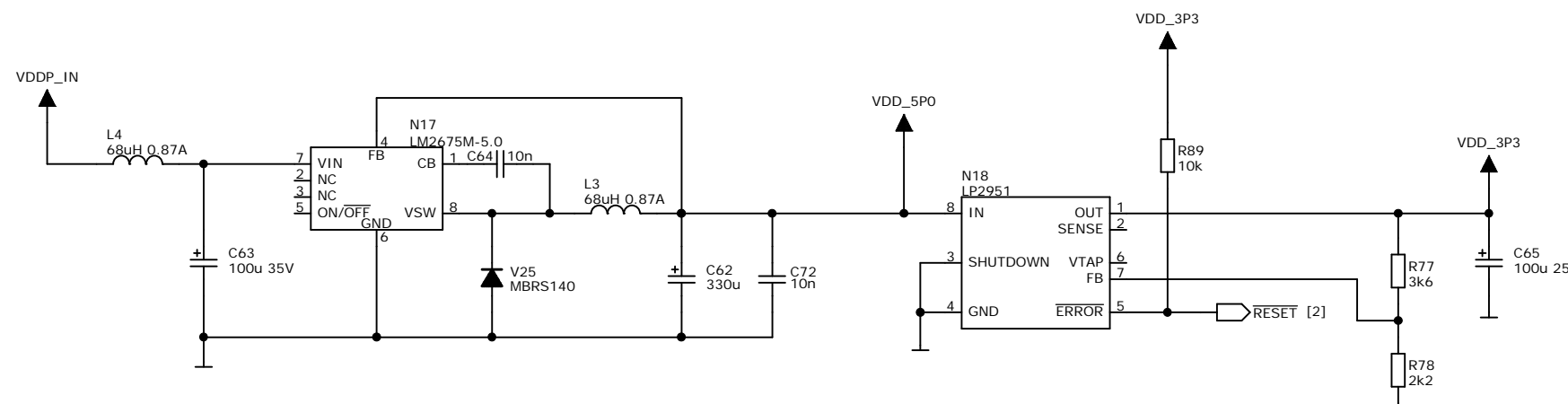

<h1>JTA Design</h1>	<h2>Crossover-amplifier-network</h2>		
	Control		
	Design date	File name	Version 01
		Sheet 2 OF 4	

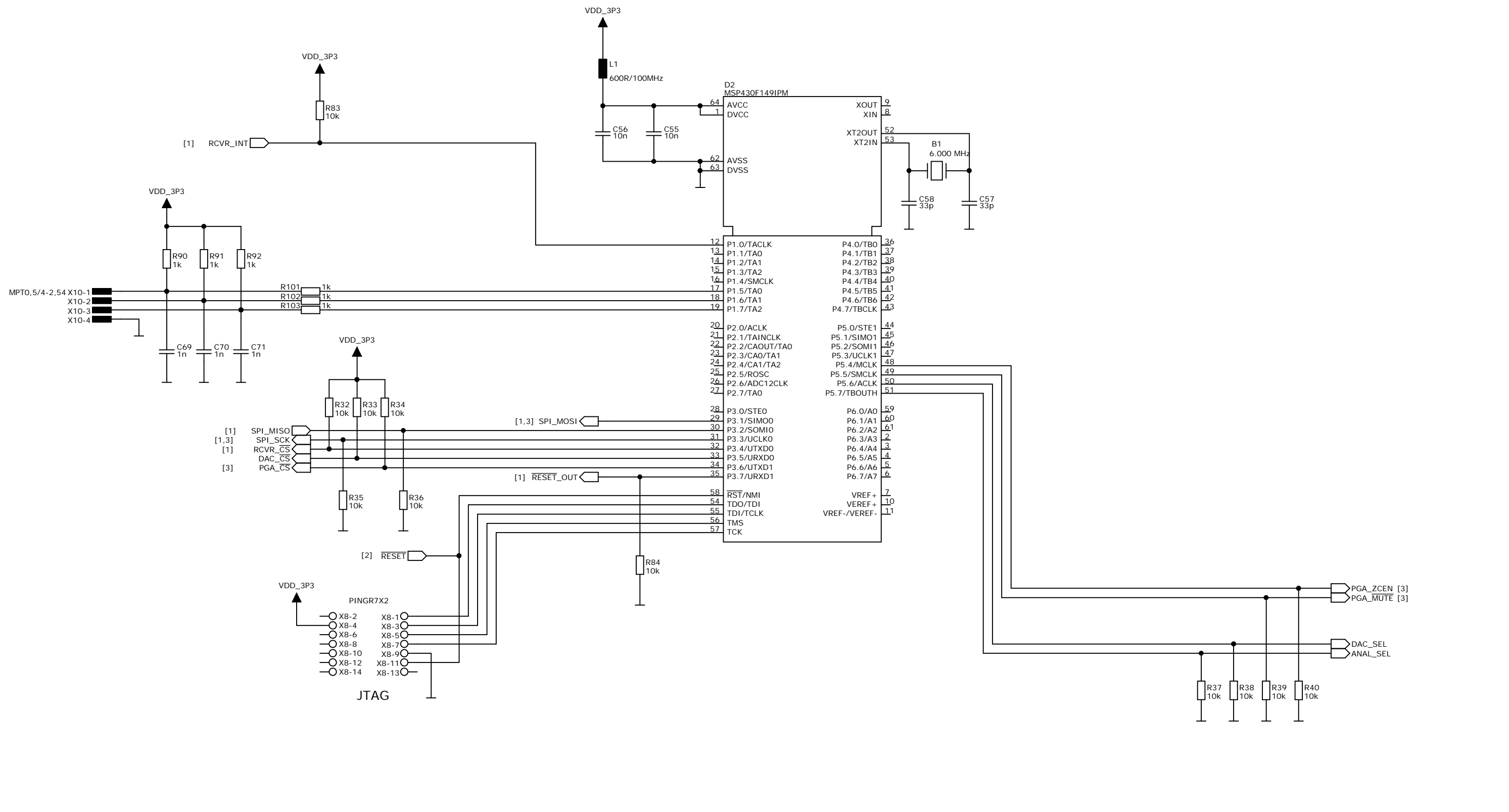
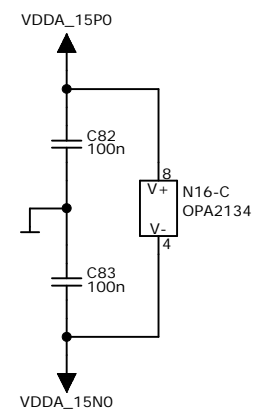
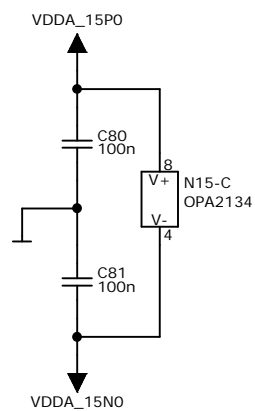
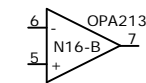
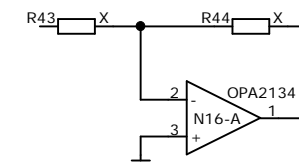
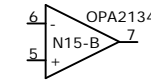
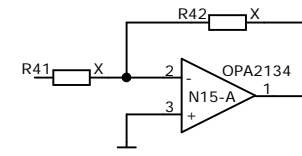
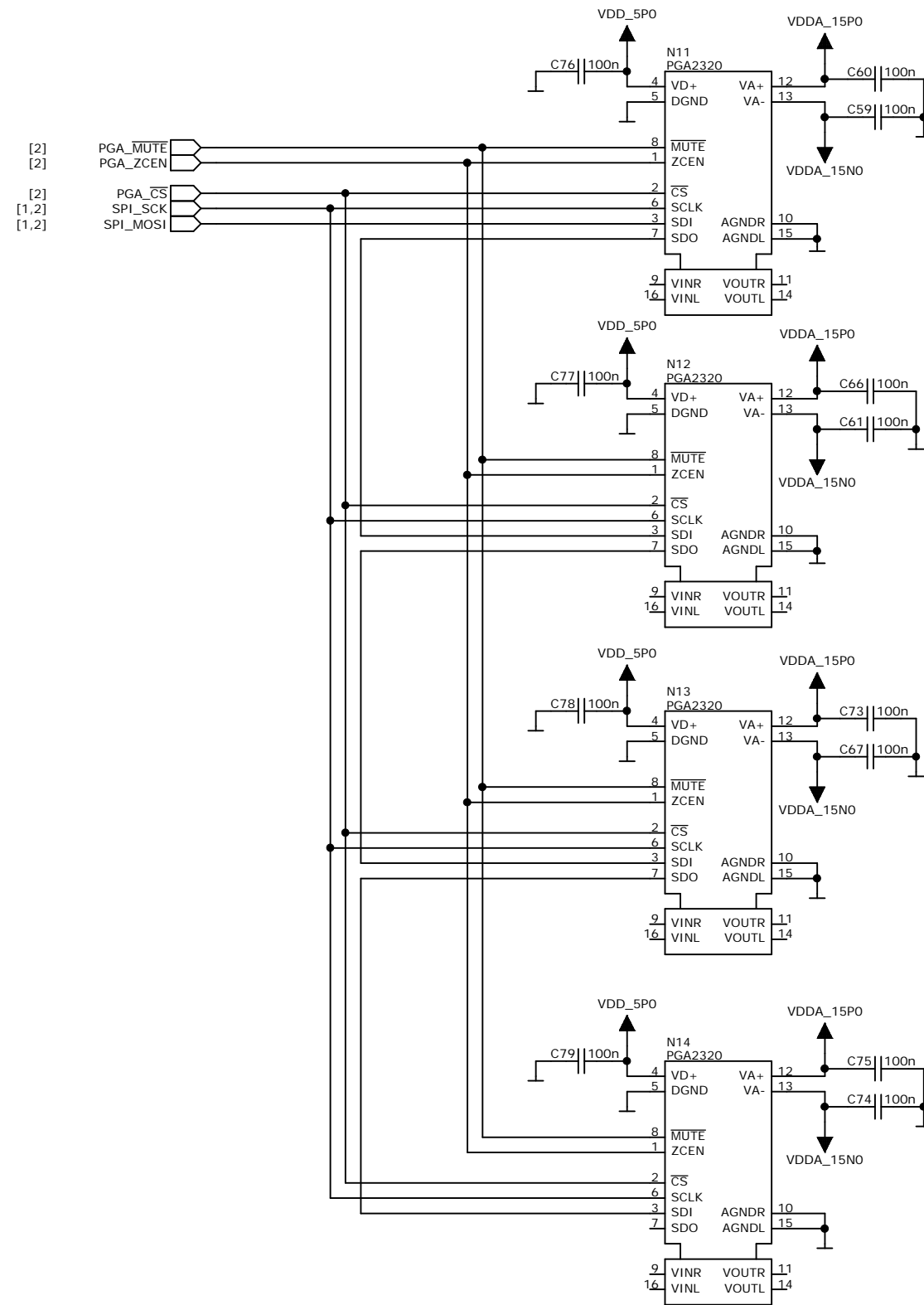

<b>JTA</b>  <b>Design</b>	<b>Crossover-amplifier-network</b> Volume Control (PGA)		
	Design date	File name	Version 01
			Sheet 3 OF 4

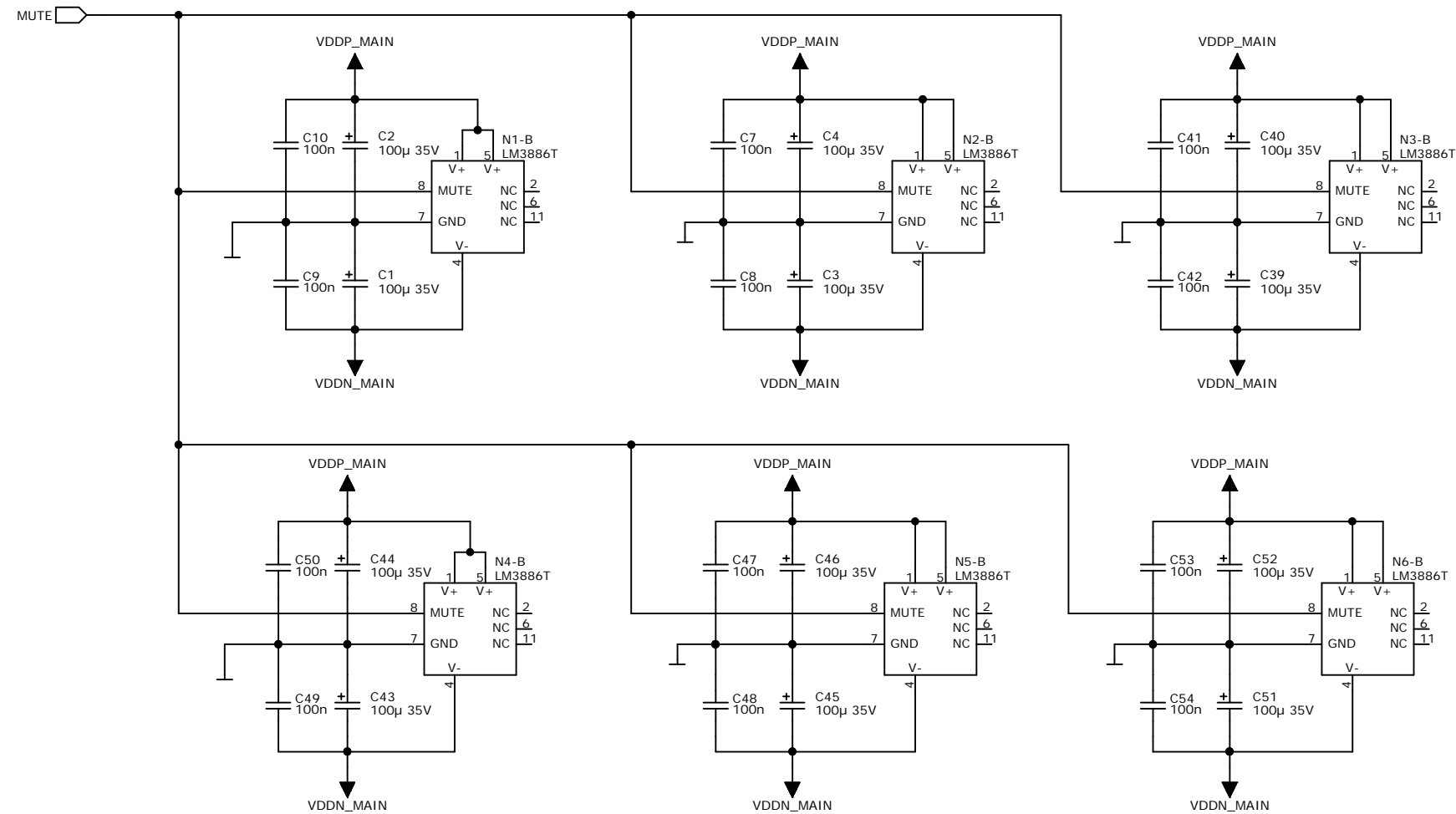
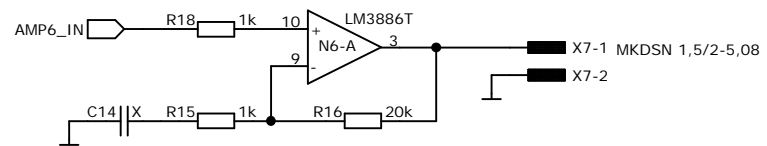
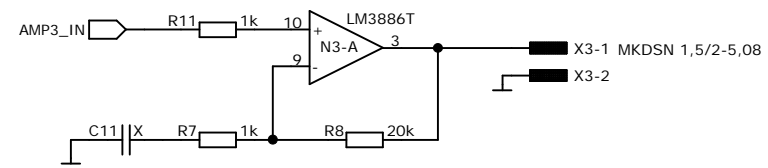
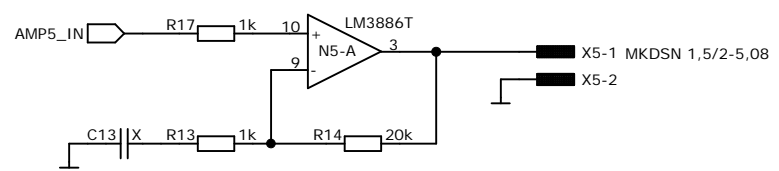
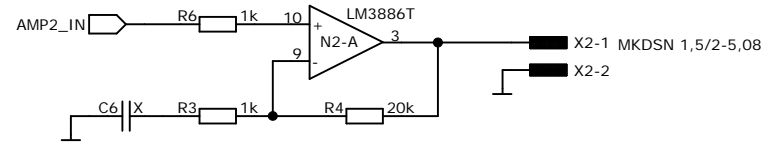
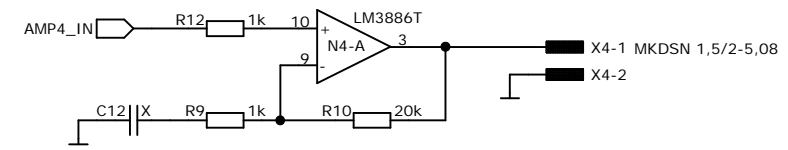
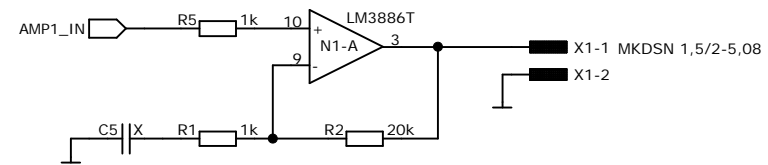

<b>JTA</b>  <b>Design</b>	<b>Crossover-amplifier-network</b>		
	Amplifiers		
	Design date	File name	Version 01
		Sheet	4 OF 4