

JTA Design	8 Channel volume control	
	Power	
	Design date 2008-11-22	File name Volume8ch.sch
	Version 01	
	Sheet 1 OF 4	

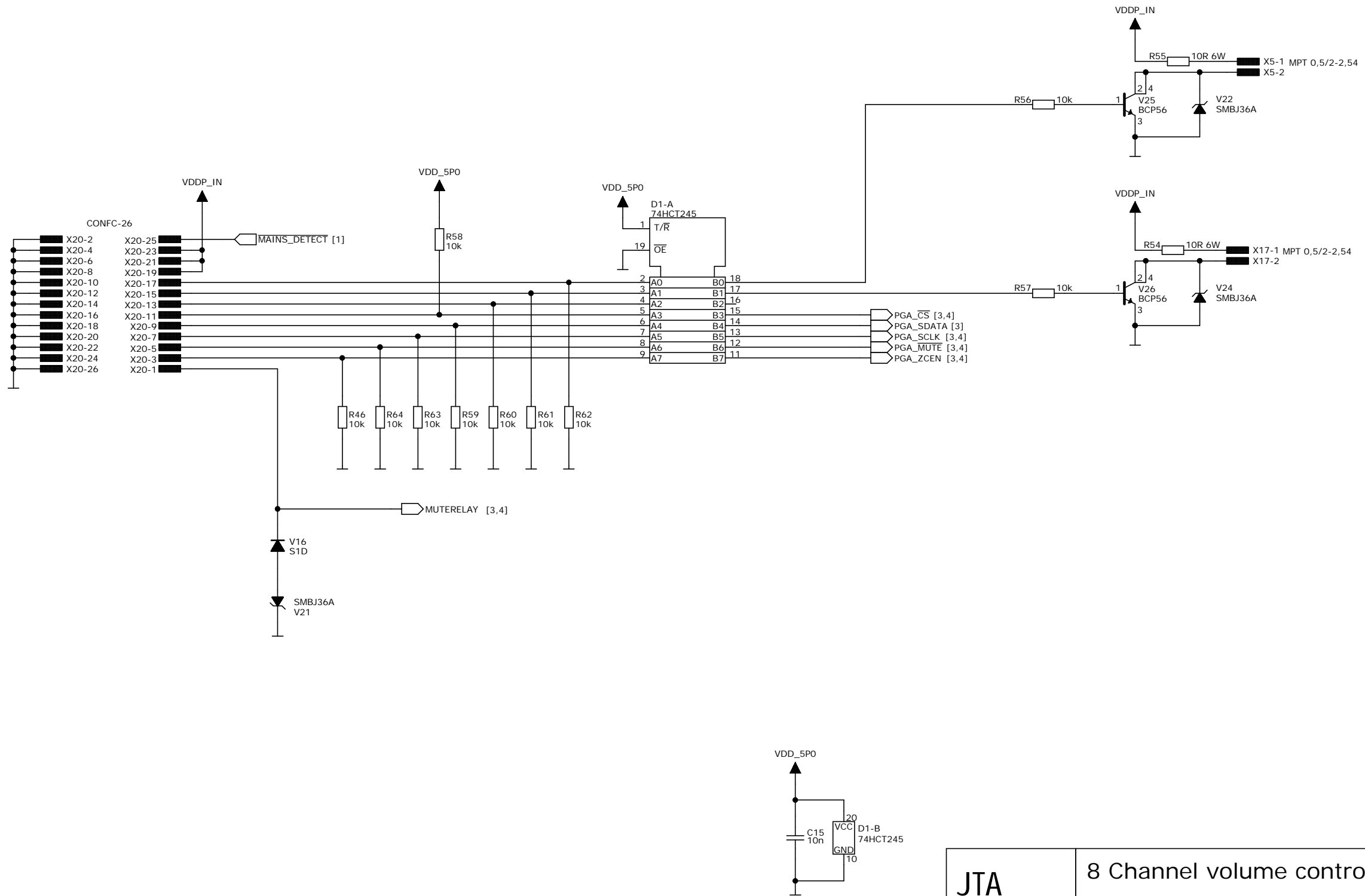

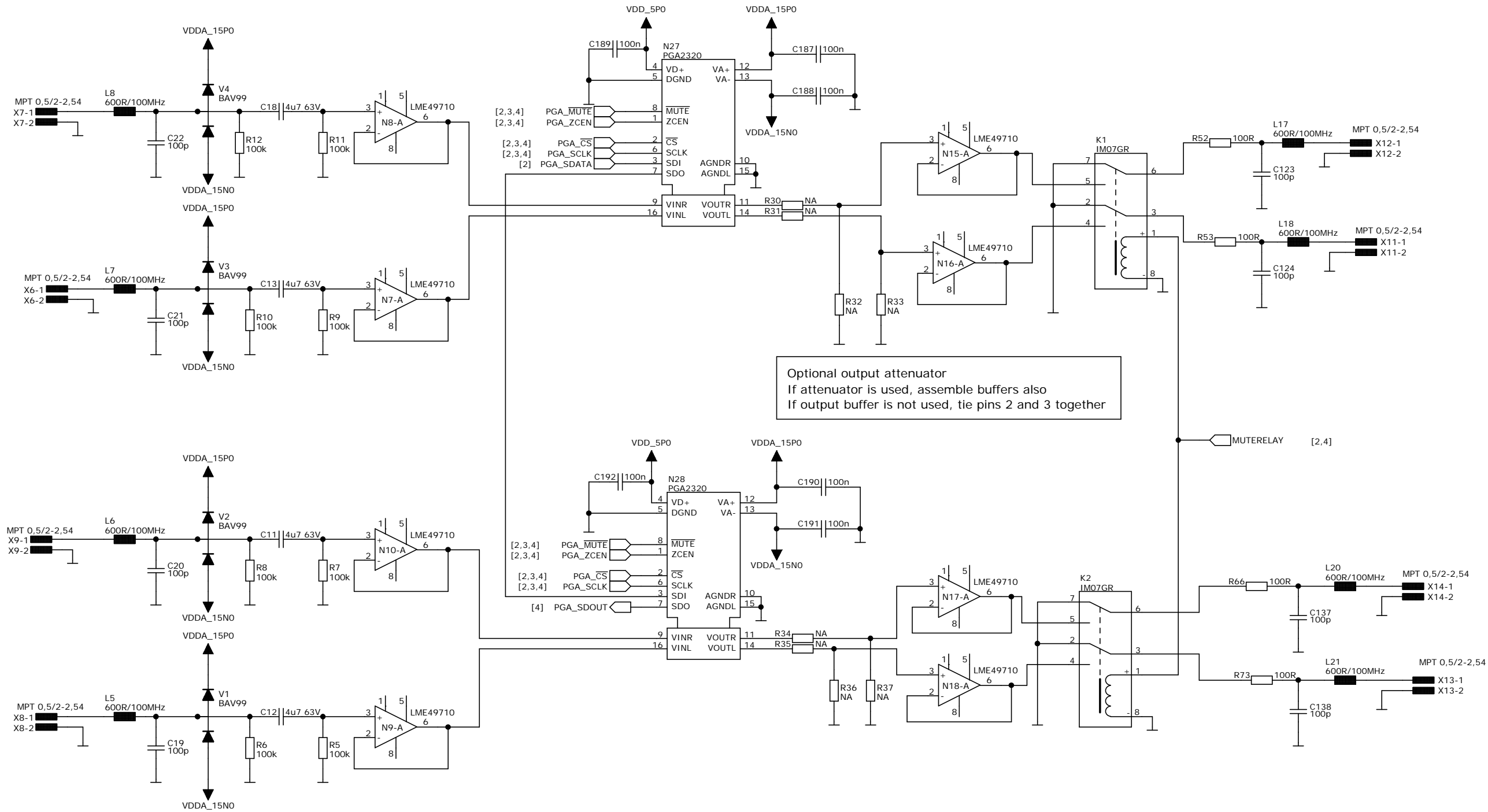

Optional output attenuator
 If attenuator is used, assemble buffers also
 If output buffer is not used, tie pins 2 and 3 together

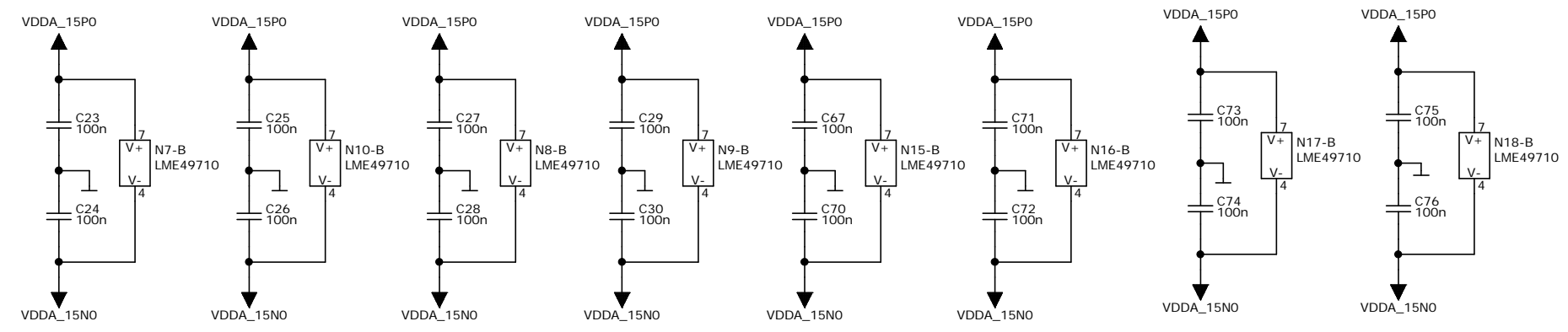
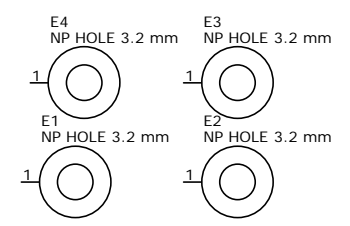

JTA Design	8 Channel volume control	
	PGA Channels 1-4	
Design date	File name	Version 01
2008-11-22	Volume8ch.sch	Sheet 3 OF 4

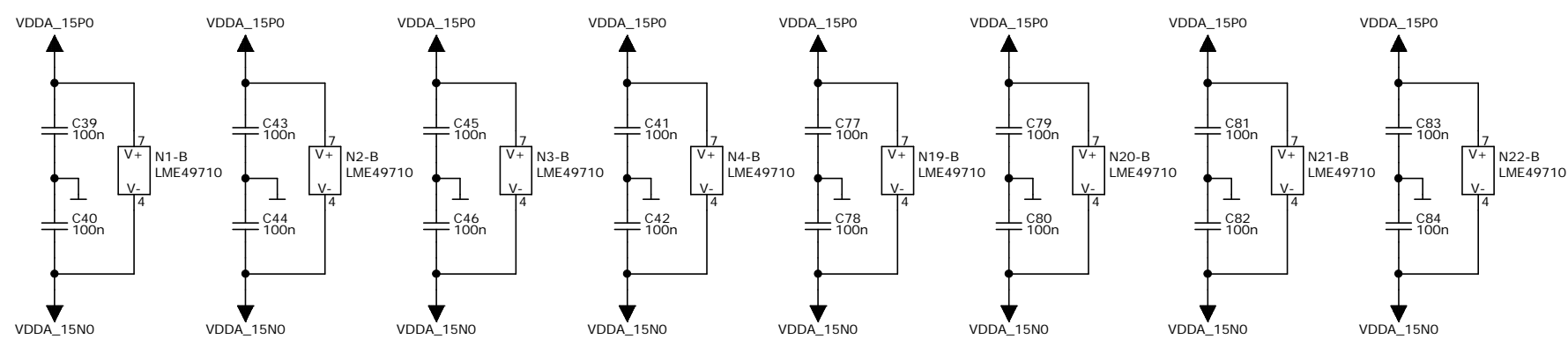
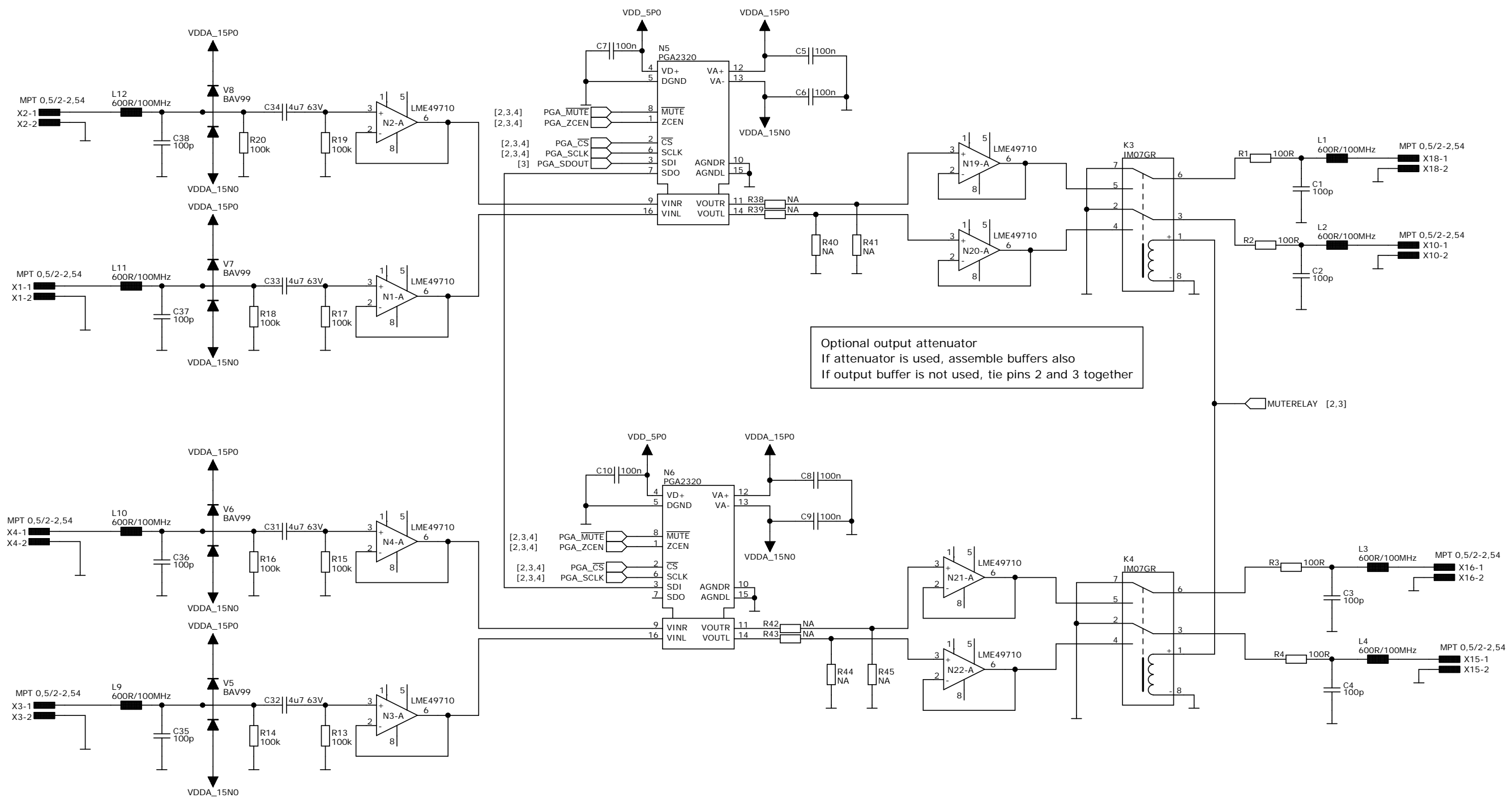

JTA Design	8 Channel volume control	
	PGA Channels 5-8	
Design date	File name	Version 01
2008-11-22	Volume8ch.sch	Sheet 4 OF 4